



INSTALLATION INSTRUCTIONS

Atmos Qube

(Thermostatic Bar Mixer Valve with Riser Rail)

Atmos Vision

(Thermostatic Bar Mixer Valve with Overhead)

Service Line Number - 0845 505 2211

INTRODUCTION

This book contains all the necessary fitting and operating instructions for your MX thermostatic bar mixer shower.

Please read these instructions carefully. Read through the whole of this book before beginning your installation.

The shower installation **MUST** be carried out by a suitably competent person and in the sequence of this instruction book.

Care taken during the installation will provide a long and trouble free life from your shower. For the best performance within the specified running pressure range a minimum flow of 8 liters per minute should be available on both inlets.

This mixer valve is designed to operate on higher pressure systems up to a maximum of 5 bar running pressure. The mixer valve must not be subjected to water temperatures above 80°C. This mixer valve is also suitable for thermal storage, unvented systems and pumped gravity systems.

IMPORTANT: Before installing with a gas instantaneous water heater, make sure it is capable of delivering hot water at a minimum switch-on flow rate of 3 liters per minute. At flow rates between 3 and 8 liters per minute, the appliance must be capable of raising the water temperature to a minimum of 52°C.

The water temperature at the inlet to the mixer valve must remain relatively constant when flow rate adjustments are made (refer to the water heater operating manual to confirm compatibility with this mixer valve).

SAFETY WARNINGS

Layout and sizing of pipework must be such that when other services are used, pressures at the shower control inlets do not fall below the recommended minimum.

DO NOT choose a position where the shower could become frozen.

DO NOT connect this mixer valve to any form of tap or fitting not recommended by the manufacturer.

The handset must be regularly cleaned to remove scale and debris.

Conveniently situated service valves in each inlet supply must be fitted as an independent method of isolating the shower should maintenance or servicing be necessary, these valves should not restrict the flow.

DO NOT operate the shower outside the recommended temperatures and pressures stated in this guide.

The British Burns Association recommends 37°C to 37.5°C as a comfortable bathing temperature for children. In premises covered by the Care Standards Act 2000, the maximum mixed water outlet temperature is 41°C.

Metal surfaces on the hot supply may become hot during operation.
Arrange to have the mixer valve regularly serviced by a suitably qualified person.

SITE REQUIREMENTS

The installation must be in accordance with Water Regulations Advisory Service (www.wras.co.uk).

Minimum running water pressure: 0.1 bar, but will operate better at a minimum of 0.5 bar.
Maximum running water pressure: 5 bar. Maximum static water pressure: 10 bar.

For your shower to perform well you should ensure that the pressure is as specified and a minimum flow of 5 liters per minute is available at both hot and cold inlets.

If a water supply is fed by a gravity then the supply pressure should be verified to ensure the conditions of use are appropriate for the valve.

NOTE: Water Regulations requires the handset to be 'constrained by a fixed or sliding attachment so that it can only discharge water at a point not less than 25mm above the spill over level of the relevant bath, shower tray or other fixed appliance'. A double check valve, or similar, **MUST** be fitted in the supply pipe work to prevent back-flow.

The pressure at both the hot and cold water supplies to the mixer valve should be the same, and the installer should ensure that the flow is not affected by other taps elsewhere in the house. It is very important that for use in any mains pressure systems an expansion tank and a pressure reducing valve has been fitted to ensure the pressure does not exceed 5 Bar. This should be confirmed by the installation engineer or competent person before installation.

WATER TEMPERATURE REQUIREMENTS

Maximum hot water temperature = 80°C, Recommended maximum = 65°C.
Minimum hot water temperature = 55°C, Maximum cold water temperature = 20°C.

TEMPERATURE ADJUSTMENT RANGE

The mixed water temperature can be adjusted from cold through to hot. There is a safety stop preset at a set temperature of about 38°C.

In the event of failure of cold water system, the mixer valve automatically reduces the flow of hot water to prevent scalding. It will only operate again once the flow of cold water has been resumed.

INSTALLATION

Before proceeding with the installation check all the components in the component list are present.

WARNING!

The shower must not be positioned where it will be subject to freezing conditions.

The mixer valve should be fitted only after all the pipework has been installed.

Do not use jointing compounds on any of the pipe fittings. Do not solder fittings near the mixer valve as heat can damage the valves seals. Always flush the system prior to installing the valve.

Before installing, make sure the mixer valve is kept in a clean place to prevent any rubbish etc. getting into the openings while fitting the pipework.

- The mixer valve is suitable for installation on a solid wall, a stud partition wall, dry lined wall or fixing to a cubicle or panel.
- The water pipes should be securely attached within the wall or panel to support the mixer valve and prevent movement or water noise after installation.
- The mixer valve hot water inlet has a red symbol next to the inlet and must be on the left hand side. If the mixer valve you are fitting is with a riser rail the outlet should point down.
- The mixer valve is designed to work at the same hot and cold water pressures. If this is not the case a flow controller (disc with small holes) can be fitted to the higher pressure supply to the valve. This is best done by testing each one to find out which gives the best results.
- The mixer valve will be installed in such a position that the maintenance of the TMV and its valves and the commissioning and testing of the TMV can be undertaken.

SITING OF THE MIXER VALVE

Position the mixer valve so that all controls can be comfortably reached while using the shower.

NOTE: Easily accessible suitable service valves (complying with Water Regulations Advisory Service www.wras.co.uk), MUST be fitted as close as practical to the valve, on the hot and cold water supplies to the shower as an independent means of isolating the water supplies should maintenance or servicing be necessary. These valves should not restrict the flow.

Before fitting the mixer valve flush out the pipework in accordance with Water Regulations Advisory Service (www.wras.co.uk).

SITING OF THE SHOWER

Having established the position of the mixer valve so that all controls can be comfortably reached whilst using the shower, the handset and riser rail can be positioned either side of the valve. Make sure any cables and pipework are not behind the required screw holes.

There is one option available with this mixer valve:

- Bar valve with Riser Rail - *Atmos Qube*
- Bar valve with Overhead - *Atmos Vision*

Consult the illustration below to make sure you check from the component list that all the parts for your system are supplied.

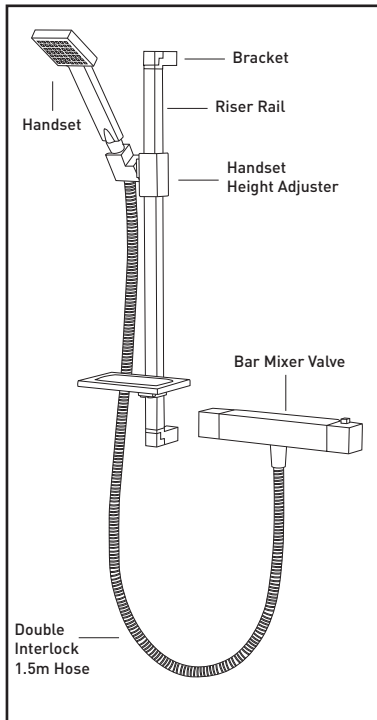

Atmos Qube
Bar valve with Riser Rail

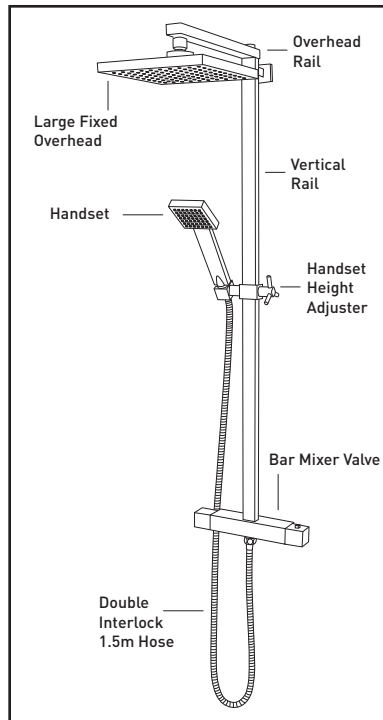

Atmos Vision
Bar valve with Overhead

FITTING OF THE MIXER VALVE

1. The supply pipework can be plumbed from above or below but must finish at the suitable connections, which should be at 150mm centers. A standard wall plate kit can be purchased to make installation easier if required. Connect the 15mm pipework using standard compression fittings (See Fig 1).
2. Screw the supplied domed cover onto the dogleg fittings until tight to the wall. If required put a bead of silicone sealant around the inside of the domed cover to prevent moisture entering the wall. The domed cover can be adjusted depending on the length of exposed thread from the elbow (See Fig 2).
3. Offer the mixer valve to the fittings, making sure the sealing washers are in place, screw the unions onto the fittings. The mixer valve must be positioned horizontally with the hot supply on the left hand side of the outlet (See Fig 3).

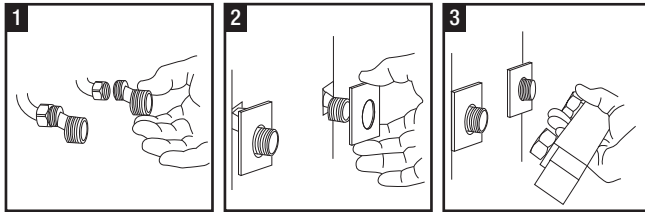

RISER RAIL FITTING FOR Atmos Qube

NOTE: Ensure you have the correct valve with the water outlet on the bottom when the hot water inlet is to the left.

4. Having established the position of the mixer valve so that all controls can be comfortably reached whilst using the shower, the handset can be positioned either side of the riser rail (See Fig 4). Make sure any cables and pipework are not behind the required screw holes.
5. Remove caps for the riser rail wall brackets, mark the position of the holes and drill, plug and screw to fit the two wall brackets. Fix lower bracket to wall (See Fig 5 & 6).

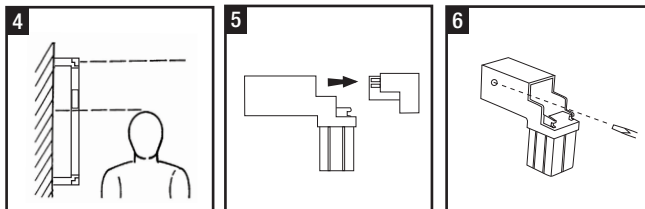

6. With the handset height adjuster on the left hand side, fit the hose retaining ring and then the soap dish, onto the bottom of the rail assembly (See Fig 7 & 8).
7. Replace the rail assembly onto lower bracket. Fix the top bracket to wall and then loosen lower bracket and fit rail into top bracket ensuring the slot locates into the notch and retighten the lower bracket. Refit caps onto brackets.

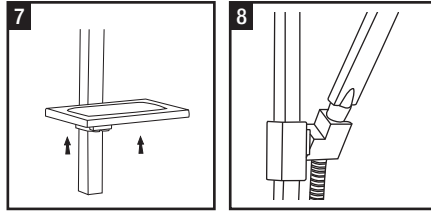

FITTING THE DOUBLE INTERLOCK HOSE AND HANDSET *Atmos Qube*

8. Connect one end of the double interlock hose to the outlet on the mixer valve, making sure that the sealing washer is in place (See Fig 10).
9. Screw the remaining end of the double interlock hose to the handset, then locate the handset into the handset height adjuster making sure the sealing washer is in place (See Fig 11). Carry out a leak test.

NOTE: It is the conical end of the double interlock hose which grips into the handset height adjuster. The handset will not fit in the height adjuster without the double interlock hose attached. The handset height adjuster grips the conical nut on the double interlock hose.

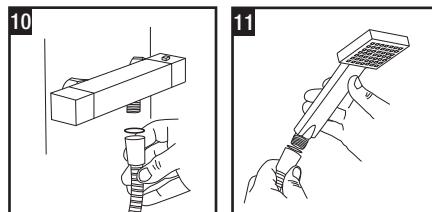

FITTING THE VERTICAL RAIL ASSEMBLY TO MIXER VALVE FOR *Atmos Vision*

10. Slide the height adjuster on to the vertical rail and lock in place. (See Fig 12).

NOTE: Ensure you have the correct valve with the vertical rail water outlet on the top and the threaded outlet facing down when the hot water inlet is to the left.

11. Attach the vertical rail to the valve and secure using small allen key supplied. Then mark the position for the vertical rail bracket. (See Fig 13).

12. Attach the top overhead rail to the vertical rail and screw until hand tight. The 'O' ring provides a seal so it does not need to be overtightened. (See Fig 14).

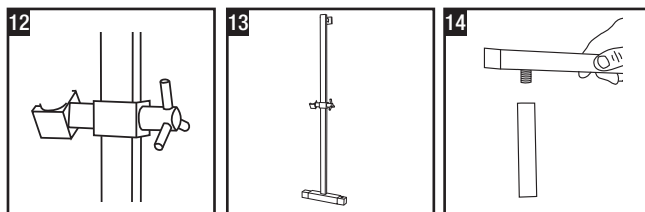

NOTE: Ensure the rail is vertically above the valve using a spirit level.

13. Ensure there are no cables or pipework behind the wall bracket position. Remove the vertical rail and position the wall bracket in the marked position. Mark the 2 hole positions for the screws. Drill and plug the wall. (The wall plugs are suitable for most brick walls - use an appropriate masonry drill. If the wall is plasterboard or a soft building block, use suitable wall fixings and a drill bit, not supplied).

14. Attach the overhead rail assembly to the top of the valve. Secure by tightening the screw on the side of the vertical rail with the small allen key supplied. (See Fig 15).

15. Secure vertical rail bracket to wall using the pre drilled holes.

FITTING THE LARGE FIXED SHOWERHEAD FOR *Atmos Vision*

16. Screw the large fixed showerhead to the overhead assembly. Make sure the sealing washer is in place and screw tight to seal the joint. (See Fig 16).

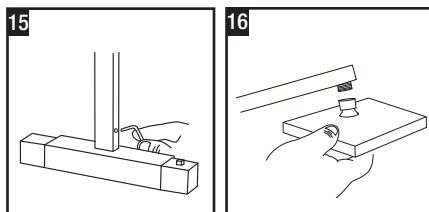

FITTING THE DOUBLE INTERLOCK HOSE AND HANDSET FOR *Atmos Vision*

17. Connect one end of the double interlock hose to the outlet on the mixer valve, making sure that the sealing washer is in place.
18. Screw the remaining end of the double interlock hose to the handset then locate the handset into the handset height adjuster. Carry out a leak test.

NOTE: It is the conical nut of the hose which grips into the handset height adjuster. The handset will not fit in the height adjuster without the hose being attached.

COMMISSIONING AND ANNUAL MAINTENANCE TESTING

On commissioning carry out the following checks and tests:

- All the pipe work has been flushed through before fitting the valve
- The valve you have purchased matches the installation
- The supply pressures and temperatures are checked and all are in the range specified in the instructions
- The isolation valves and strainers are fitted and clean of any unwanted material and do not restrict flow

Ensure both isolation valves are fully open. Turn the temperature control to cold and turn the flow on. Check the temperature is at the required minimum. Rotate the temperature controller gradually until it reaches the preset stop let it flow until the hot water has reached the valve and the temperature has stabilized. Check the temperature is $38^{\circ}\text{C} \pm 2^{\circ}\text{C}$. This is the valves factory preset.

Override the stop by pressing the button and rotate to maximum being careful to avoid scalding. Measure the temperature.

The valve should then be checked to confirm the water isolation performs correctly. Run the valve at the 38°C stop position. Check the water temperature. Turn off the feed of cold water using the isolation valve. The water flow should fall to a very low flow, (possibly only a drip) after a few seconds. Collect the water after 5 seconds and 30 seconds and measure the temperature it should be below $46^{\circ}\text{C} \pm 2^{\circ}\text{C}$. Turn on the cold water again and it should return after a few seconds to stabilise to $38^{\circ}\text{C} \pm 2^{\circ}\text{C}$

Adjustment of the temperature settings is only to be carried out by a competent TMV engineer as it is a technically difficult operation in which the valve can be easily broken. It can be done by removing the handle on the temperature controller, (noting carefully the assembly of the components), rotating the internal stops a few degrees in the required direction and then reassembling. All the commissioning checks should be redone again to ensure it now meets the required specification before using the shower.

ACCESSORIES KIT SPARE PARTS

Atmos Qube

36HMC	Bar Mixer Valve
27DGB	Double Interlock 1.5M Hose
36HHE4	Wall Brackets
36HHE1	Riser Rail
36HLT-W	Washers
36HDP	Handset
36HHE3	Hose Retaining Ring
36HHE5	Handset Height Adjuster
36ACC	Flow Controller
36HHE2	Soap Dish

ACCESSORIES KIT SPARE PARTS

Atmos Vision

36HMC	Bar Mixer Valve
27DGB	Double Interlock 1.5M Hose
36ACX	Vertical Rail
36ADB	Overhead Rail
36HLT-W	Washers
36HDP	Handset
36HHE3	Hose Retaining Ring
36HHE5	Handset Height Adjuster
36ACC	Flow Controller
36HHE2	Soap Dish
36HEU	Square Overhead

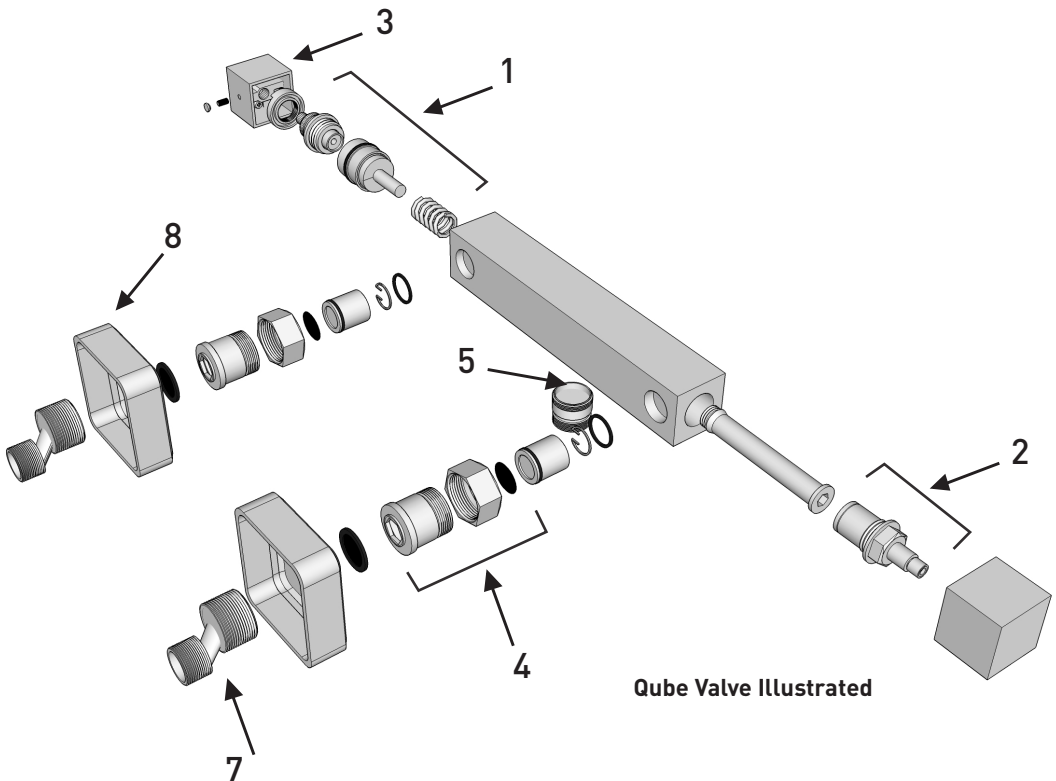

VALVE SPARE PARTS LIST

- | | | | |
|----------------|---------------------------------------|-----------------|--|
| 1. HMC1 | Thermostatic Cartridge and Spring Set | 6. HLT6 | Seal Kit, includes all 'O' rings, non-return valves, filters/filter washers and spring clips |
| 2. HMC2 | Flow Cartridge | 7. 36ACE | Dogleg Fittings |
| 3. HMC3 | Temperature/Control Knobs | 8. HMC7 | Domed Caps |
| 4. HMC4 | Union Nut and Body | | |
| 5. HMC5 | Outlet Connector with 'O' Ring | | |

<u>PROBLEM</u>	<u>POSSIBLE CAUSE</u>	<u>SUGGESTED ACTION</u>
1. Water too hot.	A Temperature control is not correctly commissioned.	Adjust the temperature control - this is only a job for a suitably qualified person.
	B Not enough cold water flowing through shower.	Turn temperature control anti-clockwise.
	C Increase in the ambient cold water temperature.	Turn temperature control anti-clockwise.
	D Cold water supply blocked.	Turn off shower and consult a competent plumber.
	E High volume of cold water drawn off elsewhere.	Reduce the simultaneous demand from the supply.
	F Cold water filter blocked.	Remove valve and clean filters.
2. Water too cold.	A Temperature control is correctly commissioned.	Adjust temperature control.
	B Not enough hot water flowing through shower.	Turn the temperature control clockwise.
	C Decrease in the ambient cold water temperature.	Turn the temperature control clockwise.
	D Hot water filter blocked.	Remove valve and clean filters on the inlet.
	E Insufficient hot water supplies from the heating system.	Make sure the hot water is available by trying a hot water tap elsewhere in the house.
	F Hot water supply blocked or restricted.	Turn off shower and consult a suitably competent plumber.
	G Pressure in excess of max recommended.	Fit pressure reducing valve.

<u>PROBLEM</u>	<u>POSSIBLE CAUSE</u>	<u>SUGGESTED ACTION</u>
3. Water does not flow or shower pattern collapses when another outlet is turned on.	A Water supplies cut off	Check elsewhere in house and if necessary contact local water company.
	B Blockage in pipework.	Turn off shower and consult a suitably competent plumber.
	C Valve filters blocked by debris in water supply.	Remove valve and clean filters.
	D Showerhead blocked.	Clean Showerhead.
	E System not capable of supplying multiple outlet at the same time.	Reduce simultaneous demand. Check stop/service valves are fully open. Check if enough water pressure.
4. Shower controls noisy whilst in use.	A Running pressure in excess of maximum recommended.	Fit reducing disc to outlet of valve.
5. Shower will not shut off.	A Flow control cartridge worn.	Renew flow control cartridge see parts list.

COMPONENTS LIST

Atmos Qube (HMF)

Description	Quantity
Brass Bar Mixer Valve for Riser Rail	1
Filter washer	2
Dogleg Thread Adaptor	2
Dome Caps	2
Pressure Balance Kit	1
Flow Restrictor + Washer	1
Riser Rail	1
Riser Rail Fixing Bracket	2
Handset Height Adjuster	1
Screw Pack (2 screw + 2 plugs)	1
Single Mode Handset	1
Hose Retaining Ring	1
1.5M Hose + Washers	1
Soap Dish	1
Fitting Instructions	1
TMV Registration Card	1

Atmos Vision (HMP)

Description	Quantity
Brass Bar Mixer Valve for Overhead	1
Filter washer	2
Dogleg Thread Adaptor	2
Square Caps	2
Pressure Balance Kit	1
Flow Restrictor + Washer	1
Vertical Rail	1
Square Overhead Rail	1
Handset Height Adjuster	1
Screw Pack (2 screw + 2 plugs)	1
Single Mode Handset	1
Hose Retaining Ring	1
1.5M Hose + Washers	1
Soap Dish	1
Fitting Instructions	1
TMV Registration Card	1

MX GROUP GUARANTEE

The MX Group guarantee this product for a period of 5 years, from date of purchase, against mechanical defects arising from faulty materials or from poor workmanship, providing the product has been installed by a competent person in accordance with the fitting instructions and the unit has been used for domestic use only.

The MX Group undertake to repair or replace, at their discretion, without charge, provided the product has been properly installed, maintained and operated in accordance with the operating instructions. Any component found to be defective during this period, as the result of misuse or damage, or the effects of scaling, will not be covered by this guarantee.

This product must not be modified, repaired or taken apart except by a person authorised by the MX Group.

What is not covered:

1. Breakdown due to:
 - a) Use other than domestic use by you or your resident family
 - b) Wilful act or neglect
 - c) Any malfunction resulting from the incorrect use or quality of water or incorrect setting of controls
 - d) Incorrect installation or using components not supplied by MX
 - e) Modification of any of the components supplied by MX prior to fitting.
2. Repair costs for damage caused by foreign objects or substances or the inappropriate use of jointing compounds or blow torches.
3. Total loss of the product due to non-availability of parts or other reason, (MX will maintain stocks of spare parts for repair for at least 5 years from end of product line to cover this guarantee).
4. Compensations for loss of use of the product or consequential loss of any kind.
5. Call out charges where no fault has been found with the appliance.
6. The cost of repair or replacement of pressure relief devices, showerheads, hoses, riser rails and/or wall bracket, tiles, cubicles or any other parts installed at the same time.
7. The cost of routine maintenance, adjustments, overhaul modifications or loss or damage arising there from, including the cost of repairing damage, breakdown, malfunction caused by corrosion, furring, pipe scaling, limescale, system debris or frost.
8. Units installed other than in the United Kingdom and for domestic use.

This guarantee does not affect your statutory rights.

MX GROUP GUARANTEE SERVICE POLICY

In the event of you needing to contact the MX Group Customer Service Department, the following procedure should be followed:

1. Before telephoning on 0845 505 2211 the MX Group Customer Service Department you should ensure you have the model number (printed on the valve) and date and proof of purchase your contact details and the postcode where the unit is installed.
2. The MX Group Customer Service Department will be able to tell you whether the fault can be simply rectified by the provision of a replacement part or arrange an on site visit by a Qualified Service Engineer.
3. If a service call is required it will be booked and the date of the call confirmed. You or a representative (over the age of 18 years) must be present during the entire engineers visit. The engineer will not be able to repair or replace or advise on parts or products not supplied as part of the product.
4. A charge will be made in the event of a service call aborted by you, but not by us, or where a call under the terms of guarantee has been booked and failure is not related to product supplied by MX Group (i.e Scaling and furring, incorrect water pressure, or other plumbing problem unrelated to the normal function of the products).
5. If the product is no longer covered by the guarantee, a charge will be made for the site visit and for any parts supplied.
6. Service charges are based on the account being settled when the work is complete. The engineer will request payment. If this is not made on the day or settled within ten working days, and administration charge will be added.

SPARE PARTS

In the event that parts or maintenance is needed outside the guarantee MX will endeavour to help with this. Spare parts codes are given in the fitting instructions. By calling the Customer Service Department on 0845 505 2211 with the part number, they will be able to quote you to supply these parts, usually via our spare parts distributor.

Marleton Cross Limited Trading as The MX Group,
Alpha Close, Delta Drive, Tewkesbury Industrial Estate, Tewkesbury, Glos. GL20 8JF.
www.mx-group.com email: mixervalves@mx-group.com
Service line number: 0845 505 2211
05-11-LH