

The MX range
of Electric Showers



MAX
Group



Duo

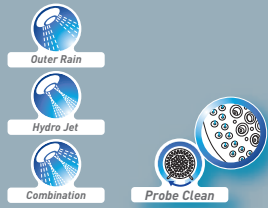

The MX Duo LXi is stunningly simple yet sophisticated. Offering the option of either a 7.5kW or 8.5kW rating, its impressive performance is enhanced by features such as full temperature stabilisation, and easy to use controls for power selection and temperature adjustment.

- Available In 7.5 kW & 8.5 kW
- B.E.A.B. Approved
- Safety High Temperature Cut Out
- Power On Indicator
- Visual Temperature Indicator
- Set & Forget Temperature Control
- Visual Power Indicator
- 3 Mode Rub Clean Handset
- Multi Entry Facility For Plumbing & Electrics
- 2 Year Guarantee
- Optional Extended 3 Year Guarantee

Exhilarating



Inspiration

A powerfully slim and stylish shower, the MX Inspiration LXi is available in 8.5kW, 9.5kW and 10.5kW. Its attractive design is guaranteed to complement any bathroom, and will meet your requirements without compromise. Features include full temperature stabilisation, 'Set & Forget' temperature control and visual temperature indicators.

Available In 8.5 kW, 9.5 kW

- & 10.5 kW
- B.E.A.B. Approved
- Safety High Temperature Cut Out
- Push Button Stop Start
- Power On Indicator
- Visual Temperature Indicator
- Set & Forget Temperature Control
- Visual Power Indicator
- 6 Mode Rub Clean Handset
- Multi Entry Facility For Plumbing & Electrics
- 2 Year Guarantee
- Optional Extended 3 Year Guarantee



Refreshing





Desire

Invigorating



The top of the range MX Desire LXi uses sophisticated electronics for the ultimate in safe and intense showering. Available in 8.5kW and 9.5kW, the tactile push button operating system with illuminated display is simple and easy to operate. The 'Stop' button incorporates phased shutdown, which ensures the flushing of all hot water out of the system. These state of the art features make the Desire LXi an unbeatable choice.

Available In 8.5 kW & 9.5 kW

- B.E.A.B. Approved
- Safety High Temperature Cut Out
- Push Button Stop Start
- Power On Indicator
- Electronic Controls
- Visual Temperature Indicator
- Set & Forget Temperature Control
- Visual Power Indicator
- 6 Mode Rub Clean Handset
- Soap Dish
- Multi Entry Facility For Plumbing & Electrics
- 2 Year Guarantee
- Optional Extended 3 Year Guarantee

Finishes & Features

Duo LXi

Inspiration LXi

Desire LXi

Shower Finishes

White

White/Chrome

Satin/Chrome



Features

Available In 7.5 kW	■		
Available In 8.5 kW	■	■	■
Available In 9.5 kW		■	■
Available In 10.5 kW		■	■
B.E.A.B. Approved	■	■	■
Safety High Temperature Cut Out	■	■	■
Automatic Solenoid On/Off	■	■	■
Push Button Stop Start		■	■
Power On Indicator	■	■	■
Electronic Controls		■	■
Phased Shut Down		■	■
Visual Temperature Indicator	■	■	■
Set & Forget Temperature Control	■	■	■
Auto Reset Indicator		■	■
Rotary Variable Power Selector	■	■	■
Neon Indicator For Power Selector		■	■
Visual Power Indicator	■	■	■
Low Pressure Warning Indicator		■	■
Riser Rail	■	■	■
Double Interlock Hose	■	■	■
Hose Retaining Ring	■	■	■
3 Mode Rub Clean Handset	■		
6 Mode Rub Clean Handset		■	■
Soap Dish		■	■
Multi Entry Facility For Plumbing & Electrics	■	■	■
Economy Setting	■	■	■
2 Year Guarantee	■	■	■
Optional Extended 3 Year Guarantee	■	■	■



Handwash

To complement MX Electric Showers we also offer 3 flow, a 3kW Instantaneous Electric Handwash. Impressive performance and easy to use controls for temperature adjustment. This product comes with the reassurance of a one year guarantee.



Instantaneous 3kW Electric Handwash

The 3 flow offers the ultimate in economy convenience ideal for use in domestic and commercial applications.

Operated by single temperature control with power on indicator and durable 200mm moulded 'swivel' spout.

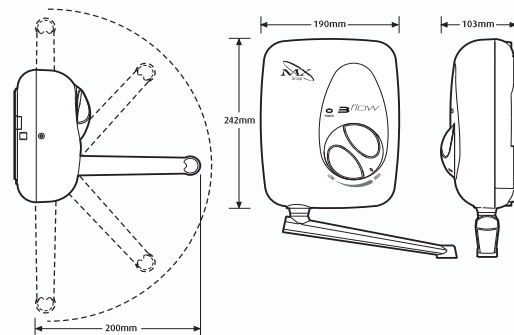

The MX Group Alpha Close, Delta Drive,
Tewkesbury Industrial Estate, Tewkesbury, Glos. GL20 8JF.
Tel: 01684 293311 Fax: 01684 293900
Email: sales@mx-group.com www.mx-group.com



BEAB
Approved

Trade Descriptions Act

Variations in terms of colour finish, materials and all other aspects of appearances may occur on occasions, either through non-availability of materials or due to our policy of continuing technical improvement. Therefore the Company reserves the right to change specification or withdraw products without prior notice being given.